

# Introduction

ID	Name	Qty
<b>Rack Components</b>		
1	Left Vertical Rail	2
2	Right Vertical Rail	2
3	Base Bracket	2
4	Corner Section	8
5	Center Section	4
6	Top Bracket	2
<b>Rack Assembly Hardware</b>		
10	M8 Bolt	48
11	M8 Washer	48
<b>Rack Assembly Tool</b>		
12	M8 (13mm) Wrench	1
<b>Equipment Mounting Hardware</b>		
13	M6 Cage Nut	50
14	PVC Cup Washer	50
15	M6 Phillips-Head Screw	50
<b>Cable Management Hardware</b>		
16	Cable Management Hook	24
17	Hook Mounting Screw	24
<b>Casters and Hardware</b>		
18	Casters	4
19	Levelling Feet	4
20	M6 Screw	16
21	M6 Flat Washer	16
22	M6 Flange Nut	16

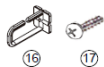
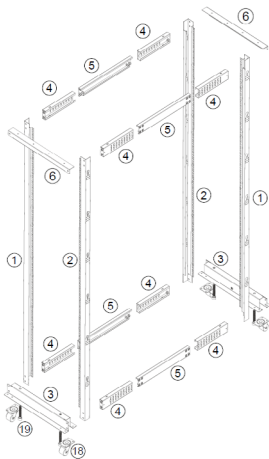

# Installation

Verify packaging contents before proceeding with assembly.

1. Assemble the Top and Bottom Beams (4 total) as shown below, adjusting for your desired mounting depth using the numbers indicated on the center section pieces (see chart below)

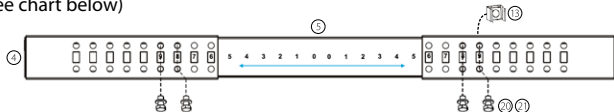

Mounting Depth	Index Numbers	Mounting Depth	Index Numbers
22 in.	0 and 0	31 in.	4 and 5
23 in.	1 and 0	32 in.	5 and 5
24 in.	1 and 1	33 in.	5 and 6
25 in.	1 and 2	34 in.	6 and 6
26 in.	2 and 2	35 in.	6 and 7
27 in.	2 and 3	36 in.	7 and 7
28 in.	3 and 3	37 in.	7 and 8
29 in.	3 and 4	38 in.	8 and 8
30 in.	4 and 4	39 in.	8 and 9
		40 in.	9 and 9

**NOTE:** Depth from 22 to 40 inches is available by adjusting the beams at corresponding silkscreen numbers on the beams.

- Using two of the Beams assembled in the previous step, line up one set of Left and Right Vertical Rails, followed by the Base and Top Bracket pieces and fasten as shown.

**NOTE:** In order to ensure all of the screw holes will line up easily, it is recommended to hand-tighten the nuts through the entire assembly process, and then fully tighten using an adjustable wrench once all bolts have been inserted.

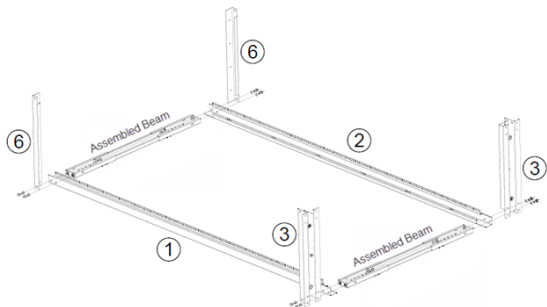

- Using the remaining two Beams assembled in step 1, line up the other set of Left and Right Vertical Rails and fasten them to the Base and Top Brackets as shown.

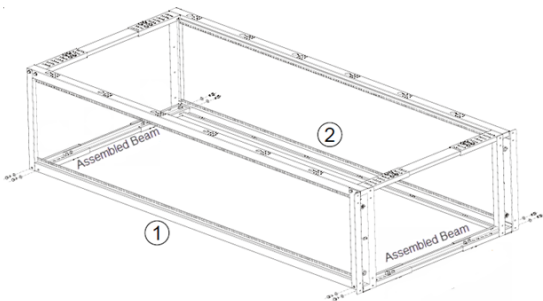

# Optional Component Installation

1. Install the Casters (4pcs) and Leveling Feet (4pcs) as shown.

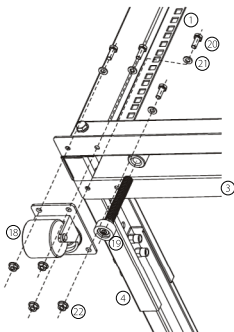

2. Stand the rack upright and install the included Cable Management Hooks in your desired locations as shown.

